

O型锻造链 Loop Chain

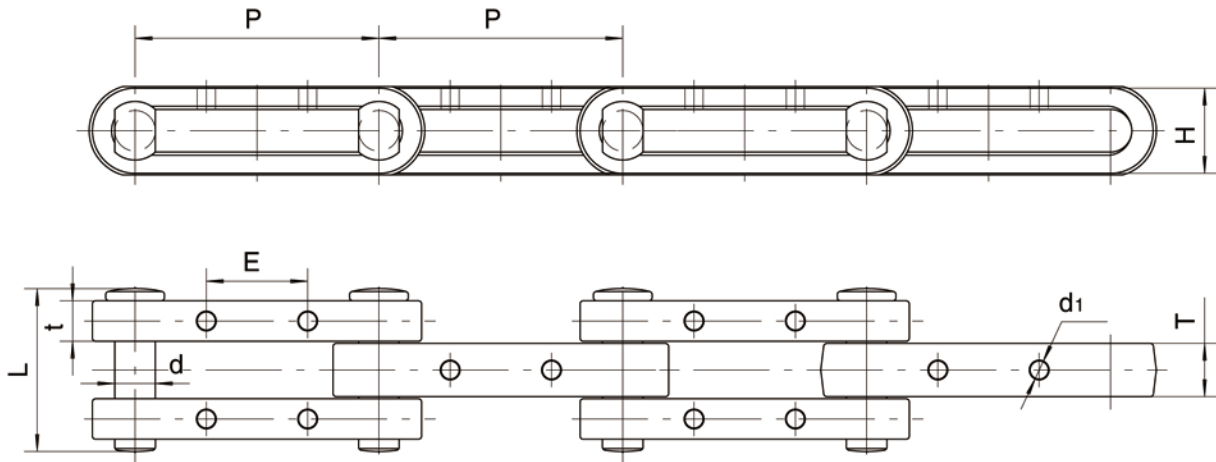

链号	节距	销轴			链板				最小抗拉强度	每米净重
Chain No.	Pitch	Pin			Sidebar				Ultimate tensile strength	Weight per meter
	p	d	L	H	t	T	d1	E	Q(min)	q
	mm	mm	mm	mm	mm	mm	mm	mm	kN	kg/m
DJ-215	152.4	39	158	77.8	38.1	50.8	17	76.2	1120	56.8
3850A	228.6	39	152	80	38	50	17	95	1000	32.05
3850B	228.6	39	132	80	40	50	17	95	1000	32.4
5075	228.6	39	201	83	50	75	17	95	1000	48.5

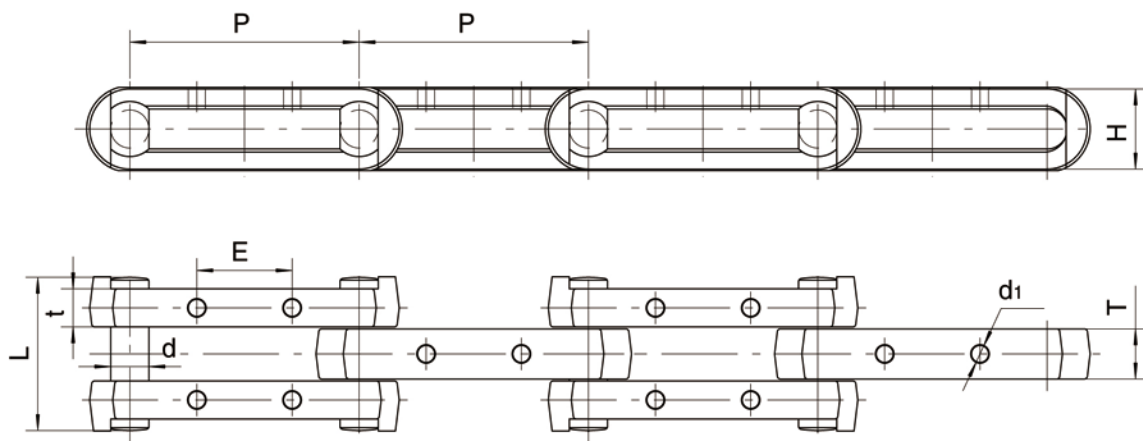

链号	节距	销轴			链板				最小抗拉强度	每米净重
Chain No	Pitch	Pin			Sidebar				Ultimate tensile strength	Weight per meter
	p	d	L	H	t	T	d1	E	Q(min)	q
	mm	mm	mm	mm	mm	mm	mm	mm	kN	kg/m
GPB152.4	152.4	30	153	63	38	50	16	76	900	34.1
KBJT152.4	152.4	39	158	72	38	50.8	17	50.8	1186.6	40.17
HG152.4	152.4	39	155	72	38	50.8	17	68	1186.6	39.95