

## FU系列刮板链 FU Series of Scraper Chains

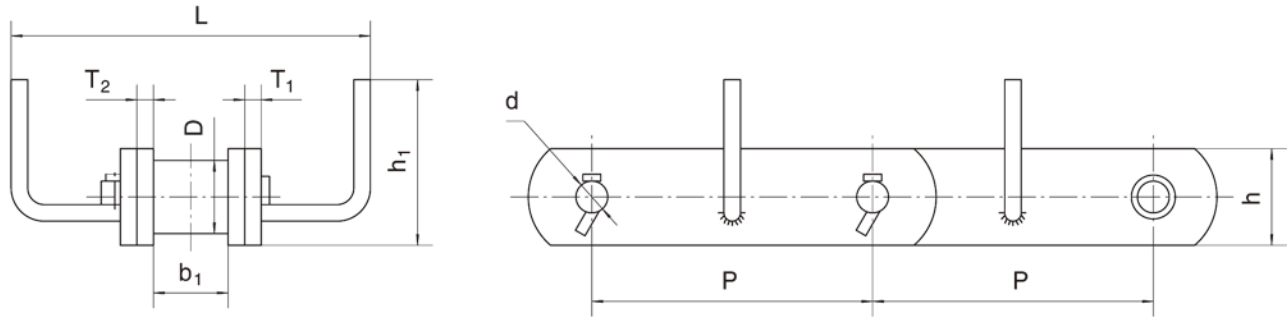

链号	节距	内节内宽	滚子外径	销轴	链板		挂钩高度	挂钩总宽	最小抗拉强度
Chain No.	Pitch	Width between inner sidebars	Roller Diameter	Pin	Sidebar		Distance between the top of scraper and the bottom of sidebar	Distance between scrapers	Ultimate Tensile Strength
	P	b <sub>1</sub> (min)	D(max)	d	h	t/T			Fu(min)
	mm	mm	mm	mm	mm	mm			mm
FU150	101.6	27	26.5	11.5	35	6	60	130	120
FU200	152.4	36.5	36	15.5	50	8	75	175	240
FU270	152.4	36.5	36	15.5	50	8	100	215	240
FU350	200	55	44.5	19	60	10	145	310	360
FU350H	200	57.6	48.5	22.2	75	10	160	320	480
FU410	200	51.8	41/44.5	19.1	60	10	160	380	360
FU410H	200	57.6	48.5	22.2	75	10	160	380	480
SSN200-U	200	60	60	30	82	12	174	416	700
FU500	300	67.5	63.5	31.75	90	12	200	457	560
FU500H	300	67.4	65	31.75	100	12	235	460	730
FU600	300	75	70	35	100	16	235	560	1000